

# Tilt Milling Vises



الطيب  
معدات والمعدات الصناعية  
AITABSH  
Machine Tools

# Tilt Milling Vises

## Features:

1. 2 Axis Machine Vises are perfect for applications that require machining on an angle.
2. These high-precision vises are constructed of close-grained, high-tensile alloy castings.
3. All boast 90 degrees vertical and 180-degree horizontal indexing, 360-degree swivel base, and 90-degree tilting range

## SPECIFICATIONS

Model	Width Of Jaw(mm)	Height Of Jaw(mm)	Max. Opening(mm)	G.w./N.w.(kgs)
160	160	50	125	37/36
125	125	45	95	28/27
100	100	41	80	18/17

header-logo

**Milling Vises**



# Milling Vises

## Description

- The vise body is made from high-quality cast irons
- The accuracy of the vise (parallelism and squareness) is 0.025mm/100mm.
- It is often used on milling machines and drilling machines to process surfaces, slots, holes, etc.

## SPECIFICATIONS

model	width of jaw(mm)	height of jaw(mm)	max of opening(mm)	G.w/N.w(kgs)
320	320	81	360	80/78
250	250	64	280	54/53
200	200	64	220	38/37
160	160	51	180	26/25
125	125	40	100	18/17
100	100	30	60	8/9

header-logo

## Drill Tilt Clamp Vises



ش  
والمعدات الصناعية  
Machine Tools

# Drill Tilt Clamp Vises

## Description

- tilting series drilling machine fixture can be adjusted and locked from the horizontal position to the vertical position (0°-90°).
- One of the main accessories of the drilling machine can be used for the processing of inclined surfaces.

## SPECIFICATIONS

model	width of jaw(mm)	height of jaw(mm)	max. opening(mm)	G. weight/N. weight(kg)
100	100	46	102	9/8
75	75	35	76	23/22

header-logo

## 3 Axis Cross Vises

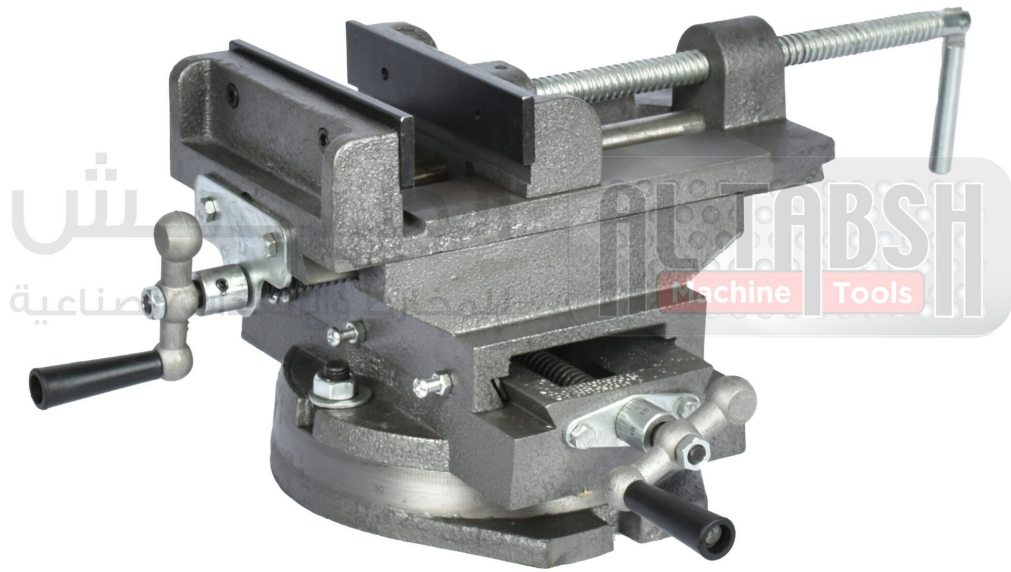

## 3 Axis Cross Vises

### Description

- Cross clamp is used in two mutually perpendicular feeding mechanisms, it can be moved in the direction of X and Y at the same time, and it can be rotated 360° with a swivel base.
- When it is compatible with a bench-type drilling machine, it can drill several holes and mill several slots. on the same face once time by the way of hand-operated feeding in two mutually perpendicular directions It can be used as an attachment for milling machine and grinding machine or as a tool used only.

## SPECIFICATIONS

model	width of jaw(mm)	height of jaw(mm)	max. opening(mm)	G. weight/N. weight(kg)
200	200	53	203	37/35
150	160	53	152	28/27
125	125	50	125	19/18
100	75	35	76	8/9

header-logo

## 2 Axis Cross Vises



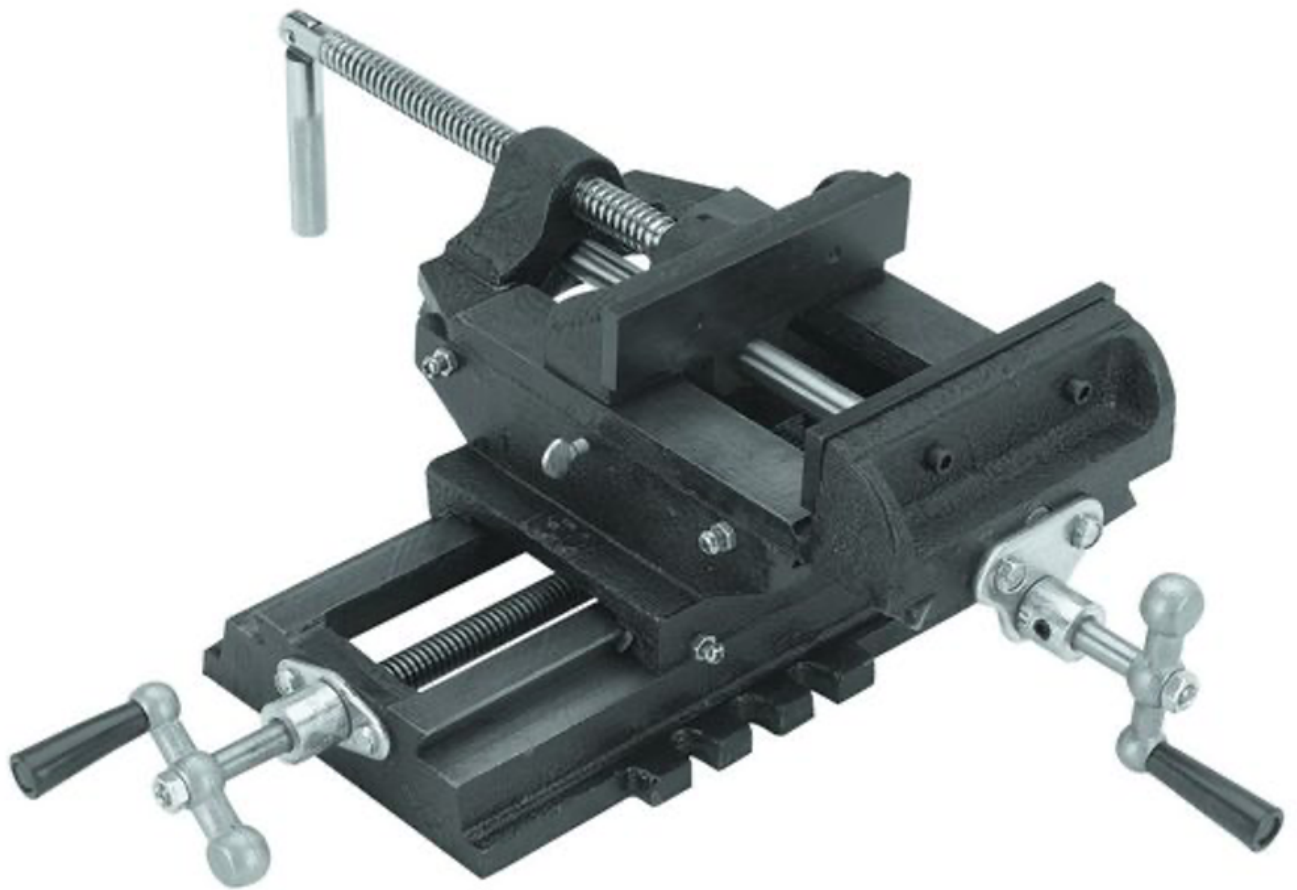

## 2 Axis Cross Vises

### Description

This machine vice is the perfect accessory for drills and milling machines and fits almost all workbenches. Whether in the local hobby cellar, the garage, or in the mobile service car: Wherever there is something to be fixed, you are well advised with this vise. Thanks to the production of cast iron and the hardened jaws, even heavy parts can be securely fixed and then processed. Grips and screws are optimally protected against rust attack by the chrome plating.

## SPECIFICATIONS

Model	Width of jaw(mm)	Height of jaw(mm)	Max. opening(mm)	N.W./G.W.(kg)
200	200	53	203	33/35
150	160	53	152	27/28
75	75	35	76	7/8

header-logo

**Drill Vises**



# Drill Vises

## Description

- Professional quality durable cast construction drill press vice, high hardness, and durability.
- Heightened and widened vice jaws for much more clamping force to keep the workpiece more stable during machining.
- Slotted base for easy installation and positioning.
- Fine machined bottom improved the precision of the contact surface between the vise and machine to ensure the precision of products.
- Widely used in milling machines, drill presses, and machinery maintenance, etc.

## SPECIFICATIONS

model	width of the jaw(mm)	height of jaw(mm)	max opening of the jaw(mm)	G. weight/N. weight(kg)
160	160	48	120	28/27
120	120	35	100	19/18

header-logo

**Swivel Bench Vises  
AST006**

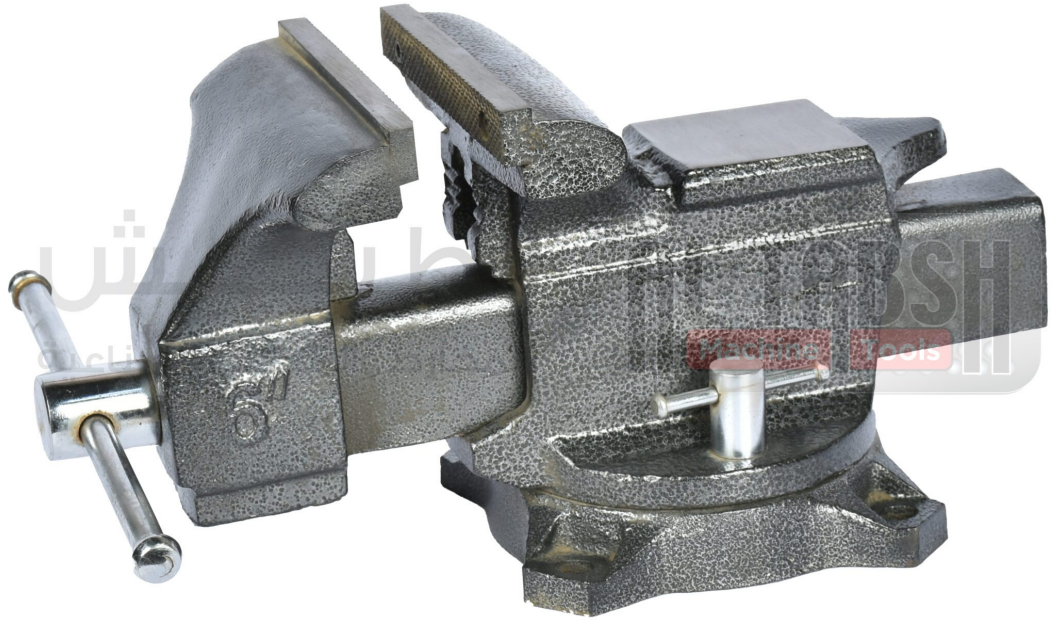

# Swivel Bench Vises

## AST006

### Features :

1. Replaceable hardened jaws
2. Permanent pipe jaws
3. Large anvil
4. Ductile iron spindle nut
5. 270-degree swivel movement
6. Chrome-finished spindle and Handel

## SPECIFICATIONS

Model	product	size	jaw open	G. weight/N. weight(kg)
AST006	Bench Vise Large Anvil Fixed Base	6"	125mm	16/17

header-logo

# Swivel Bench Vises BVS

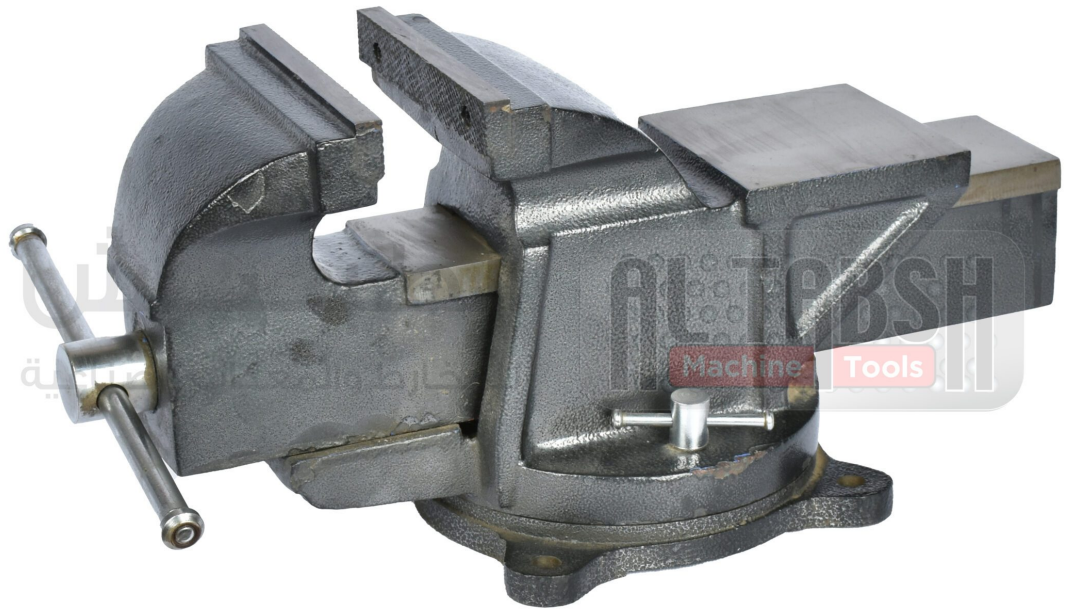

# Swivel Bench Vises BVS

## Features:

1. Replaceable Hardened jaws
2. Large anvil
3. 360-degree swivel movement
4. Chrome-finished spindle & handle

## SPECIFICATIONS

Model	product	size	jaw open	G. weight/N. weight(kg)
BVS08	Bench Vise Large Anvil Swivel Base	8"	200mm	25/24
BVS06	Bench Vise Large Anvil Swivel Base	6"	150mm	20/19

header-logo

## Fixed Bench Vises





# Fixed Bench Vises

## Features:

1. Replaceable
2. Large anvil
3. 360 degrees

## SPECIFICATIONS

Model	product	size	jaw open	G. weight/N. weight(kg)
BVF08	Bench Vise Large Anvil Fixed Base	8"	200mm	24/23
BVF06	Bench Vise Large Anvil Fixed Base	6"	150mm	19/18